

**DICHIARAZIONE DI CONFORMITÀ / DECLARATION OF CONFORMITY / DÉCLARATION DE CONFORMITÉ
KONFORMITÄTSERKLÄRUNG / DECLARACION DE CONFORMIDAD / DECLARAÇÃO DE CONFORMIDADE**

Dichiara sotto la propria responsabilità che il prodotto:

- Declares under its own responsibility that the following product:
- Déclare sous sa propre responsabilité que le produit:
- Erklärt auf eigene Verantwortung, daß das Produkt
- Declara, bajo su propia responsabilidad, que el producto:
- Declara, sob a sua responsabilidade, que o produto:

Elettroserratura	EBP, EBP 24, EBPE 24, EBPE 52, EBPE 75
Looking	EBP, EBP 24, EBPE 24, EBPE 52, EBPE 75
Electroserrure	EBP, EBP 24, EBPE 24, EBPE 52, EBPE 75
Elektroschloß	EBP, EBP 24, EBPE 24, EBPE 52, EBPE 75
Electrocerradura	EBP, EBP 24, EBPE 24, EBPE 52, EBPE 75
Sechadura electrica	EBP, EBP 24, EBPE 24, EBPE 52, EBPE 75

- È conforme ai requisiti essenziali di sicurezza delle Direttive:
- It also complies with the main safety requirements of the following Directives:
- Est conforme aux exigences essentielles de sécurité des Directives:
- Es entspricht den grundlegenden Sicherheitsbedingungen der Direktiven:
- Es conforme a los requisitos esenciales de seguridad de las Directivas:
- Está conforme aos requisitos essenciais de segurança das Directivas:

BASSA TENSIONE
LOW VOLTAGE
BASSE TENSION
NIEDERSpannung
BAJA TENSION
BAIXA TENSÃO

73/23/CEE, 93/68/CEE (EN 60335-1 (1995))

COMPATIBILITÀ ELETTROMAGNETICA
ELECROMAGNETIC COMPATIBILITY
COMPATIBILITÉ ÉLECTROMAGNÉTIQUE
ELEKTROMAGNETISCHE KOMPATIBILITÄT
COMPATIBILIDAD ELECTROMAGNETICA
COMPATIBILIDADE ELECTROMAGNÉTICA

89/336/CEE, 91/263/CEE, 92/31/CEE, 93/68/CEE
(EN 50081-1, EN50081-2)

SCHIO 01.01.1997

Il Rappresentante Legale / The legal Representative
Le Représentant Légal / Der gesetzliche Vertreter
El Representante Legal / O Representante legal

Renato Airo

BFT	FRANCE	BFT S.p.a.	ITALIA
Parc Club des Aygaldes 35 bd capitaine GEZE 13333 MARSEILLE Cedex 14			Via Lago di Vico, 44 36015 Schio (VI) Tel.naz. 0445 696511 Tel.int. +39 0445 696533 Fax 0445 696522 Internet: www.bft.it E-mail: sales@bft.it
Tel. 0491101860 Fax 0491101866			
BFT	DEUTSCHLAND		
BFT Torantriebssysteme GmbH Faber-Castell-Str. 29, 90522 Oberasbach http://www.bft-torantriebe.de			
Tel.: 0911 / 7 66 00 90 Fax.: 0911 / 766 00 99			

ELEKTROSCHLOSS



EBP - EBP E



MONTAGE- und BEDIENUNGSANLEITUNG



AZIENDA CON SISTEMA QUALITÀ
CERTIFICATO DA DNV
== UNI EN ISO 9001 ==

Via Lago di Vico, 44
36015 Schio (VI)
Tel.naz. 0445 696511
Tel.int. +39 0445 696533
Fax 0445 696522
Internet: www.bft.it
E-mail: sales@bft.it



Mod.	EBP - EBPE52 - EBPE75 - EBPE90			
Versorgungsspannung	EBP 230 230V~±10% 50/60Hz	EBP 110 110V~±10% 50/60Hz	EBP 24 230V~ 24V~±10% 50/60Hz	EBP 12 12V~±10% 50/60Hz
max. Stromaufnahme	400mA	840mA	15A	24A
Haltestrom bei angezogenem Bolzen	150mA	260mA	1,45A	3A
Betriebstemperatur	-20° ÷ +55°			
Schutzgrad	IP44			

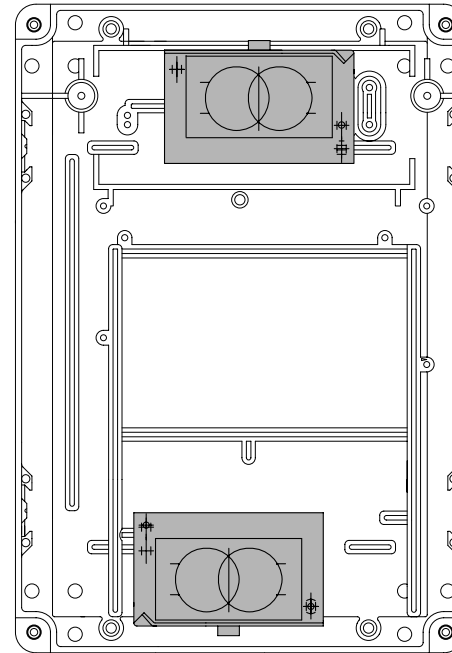
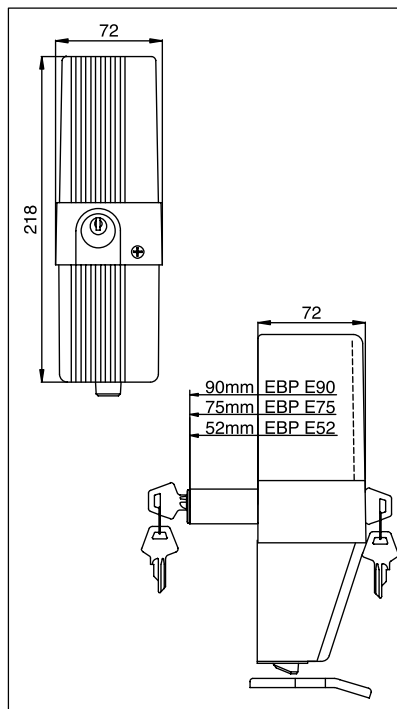

Schablone 1:1

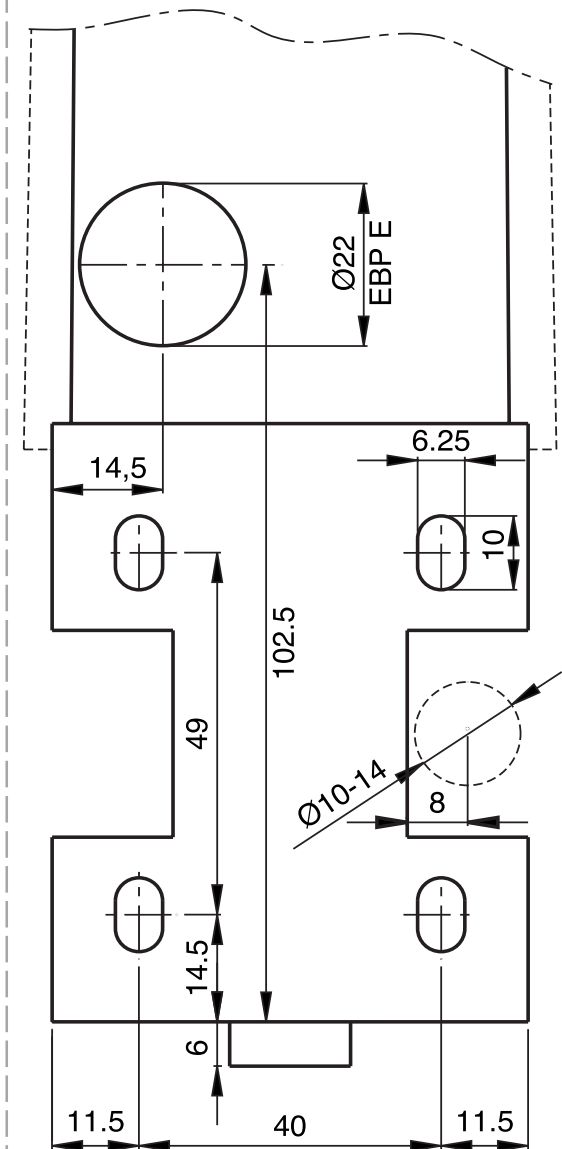

Für den Anschluß des Elektroschlösses EBP siehe die Montage- und Bedienungsanleitung der jeweiligen Steuerung, an welche das Elektroschloß angeschlossen wird.

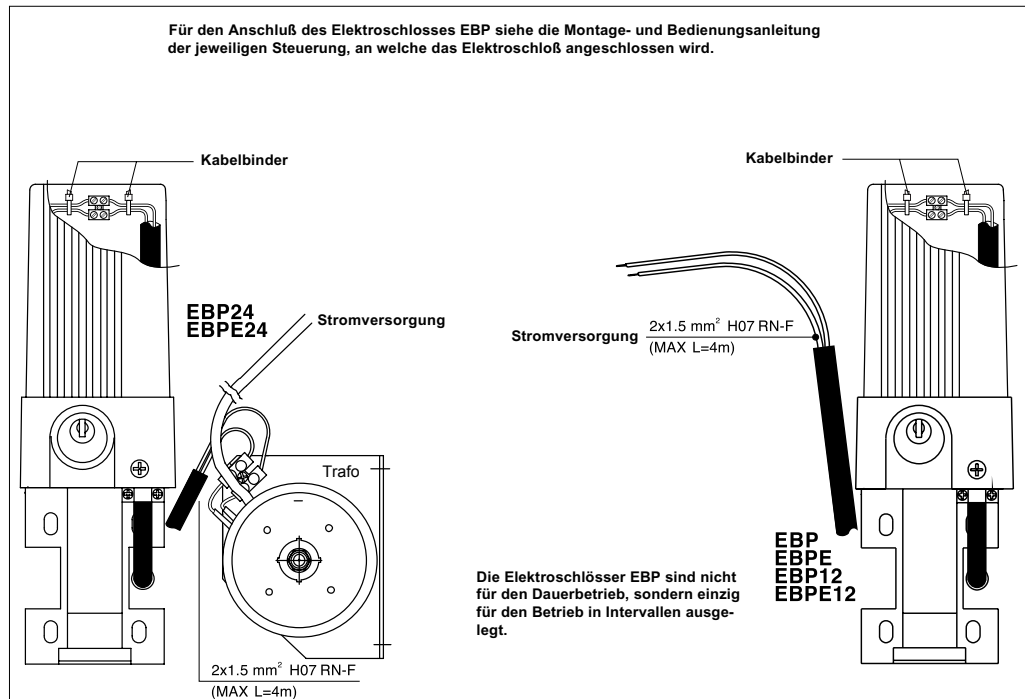

EBP24 EBPE24

